

NEXUS R3 VCU WIRING DIAGRAM

NOTES

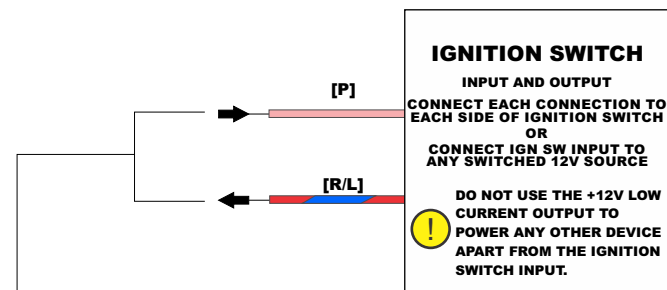

SWITCHING THE NEXUS R3 VCU ON METHOD 1 - CONNECTING TO EXISTING IGNITION KEY SWITCH WIRING

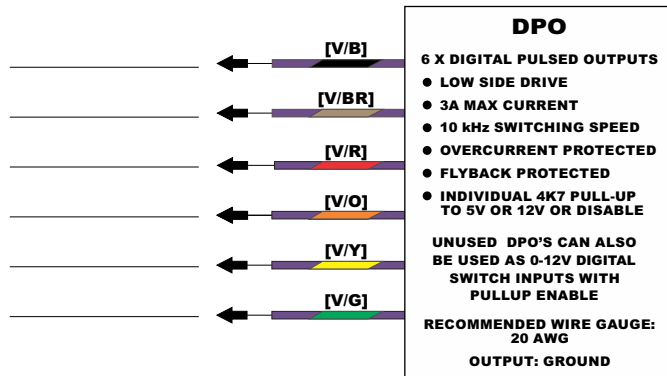
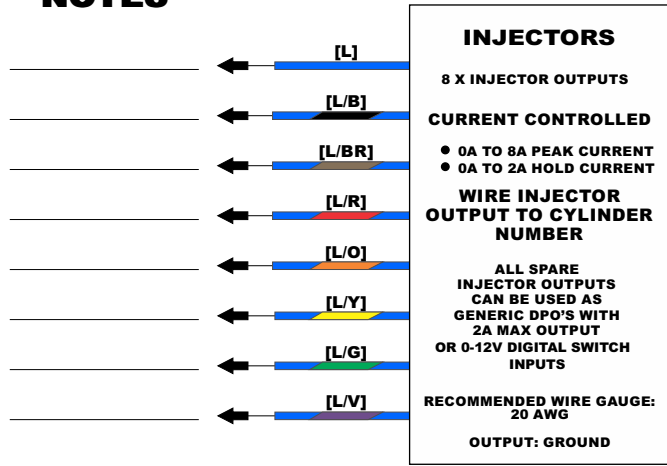
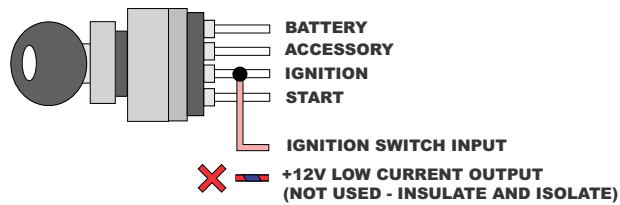

SWITCHING THE NEXUS R3 VCU ON METHOD 2 - USING A GENERIC TOGGLE SWITCH



CONNECTOR A 34 PIN KEYWAY 1

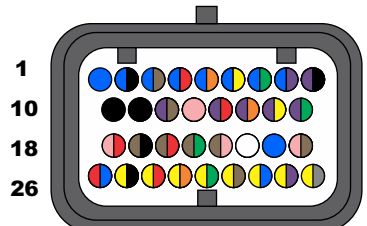

LOOKING INTO CONNECTOR ON NEXUS R3 VCU

NOTES

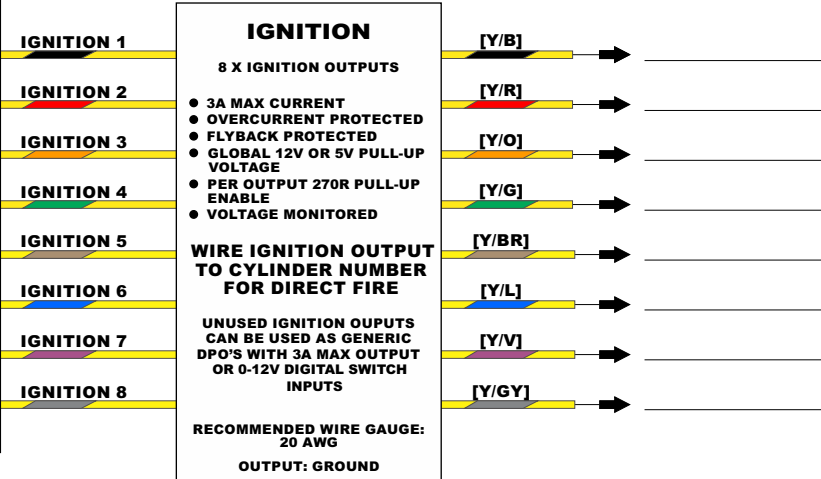
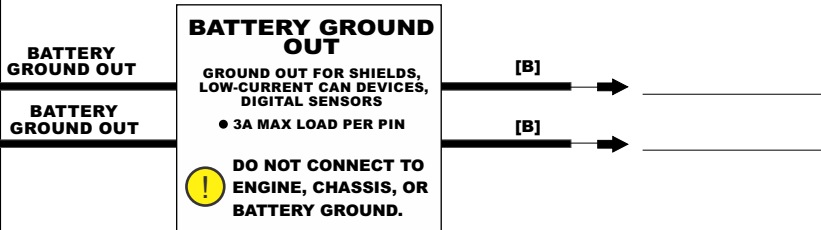
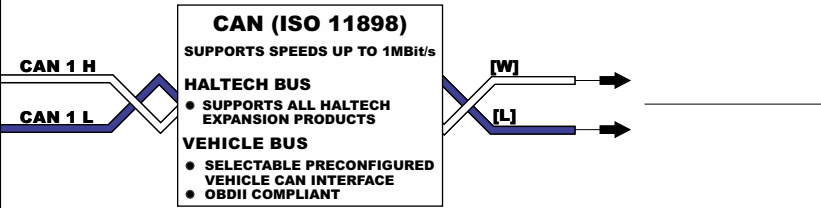
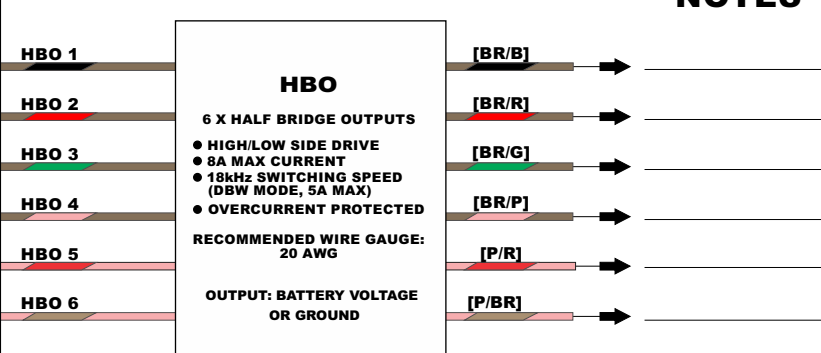

MAIN BATTERY CONNECTION

CONNECT THE POSITIVE BATTERY TERMINAL TO THE POSITIVE TERMINAL ON THE NEXUS R3 USING THE RED SURLOK CONNECTOR PROVIDED WITH THE VCU AND A RED 4 AWG BATTERY CABLE.

CONNECT THE NEGATIVE BATTERY TERMINAL TO THE NEGATIVE TERMINAL ON THE NEXUS R3 USING THE BLACK SURLOK CONNECTOR PROVIDED WITH THE VCU AND A BLACK 4 AWG BATTERY CABLE.

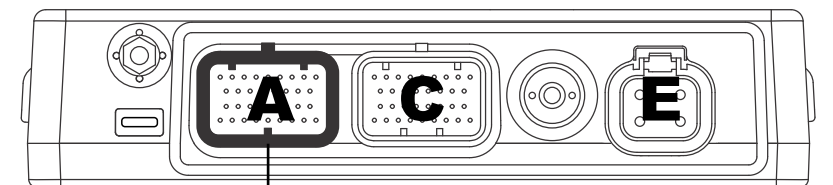
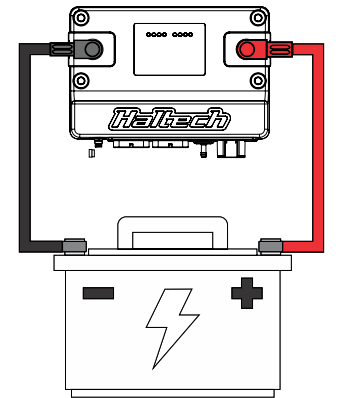

LEGEND - WIRE COLOUR
B = BLACK BR = BROWN G = GREEN GY = GREY L = BLUE
LL = LIGHT BLUE LG = LIGHT GREEN LY = LIGHT YELLOW O = ORANGE
P = PINK R = RED V = VIOLET Y = YELLOW W = WHITE
WHEN TWO COLOURS ARE USED IN A WIRE BY THE ALPHABETICAL CODE, THE FIRST LETTER INDICATES THE BASIC WIRE COLOUR, THE SECOND COLOUR INDICATES THE COLOUR OF THE STRIPE.

Haltech	
NEXUS R3 VCU WIRING DIAGRAM	
DOCUMENT REVISION: 1.0	HT-193000
DATE: JANUARY 2023	SHEET 1 OF 2

NEXUS R3 VCU WIRING DIAGRAM

NOTES

TRIGGER AND HOME INPUTS

- SUPPORTS RELUCTOR INPUTS
- SUPPORTS DIGITAL INPUTS
- SELECTABLE GROUND REFERENCE AND PULLUP TO 5V
- 48kHz MAX SIGNAL FREQUENCY

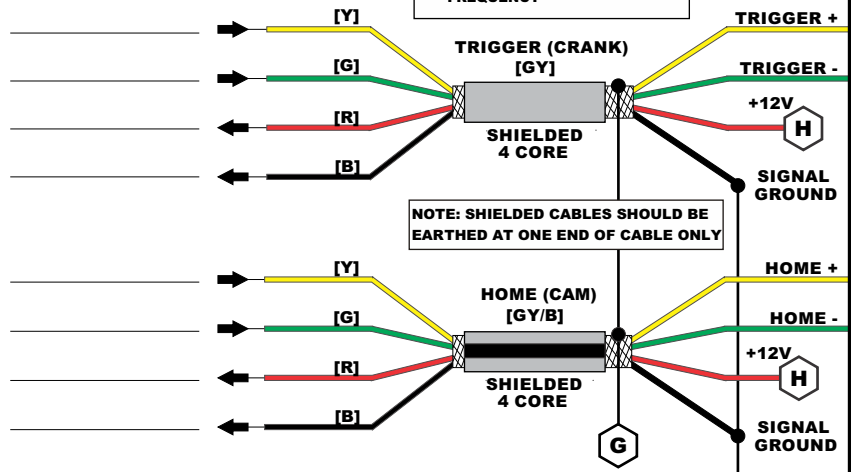

NOTE: SHIELDED CABLES SHOULD BE EARTHED AT ONE END OF CABLE ONLY

SPI

6 X SYNCHRONISED PULSED INPUTS

- SUPPORTS RELUCTOR INPUTS
- SUPPORTS DIGITAL INPUTS
- SUPPORTS 0-5V ANALOG INPUTS
- 22.5kHz MAX FREQUENCY
- 25V MAX INPUT VOLTAGE
- SWITCHABLE 1K PULL-UP

RECOMMENDED WIRE GAUGE: 22 AWG

MEASUREMENT RANGE: -10V TO 10V

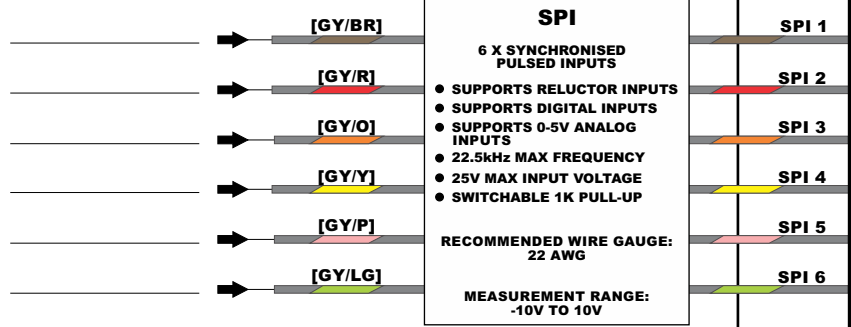

SIGNAL GROUND

- 500mA MAX OUTPUT CURRENT

SHIELDED 2 CORE [B/L]

NOTE: SHIELDED CABLES SHOULD BE EARTHED AT ONE END OF CABLE ONLY

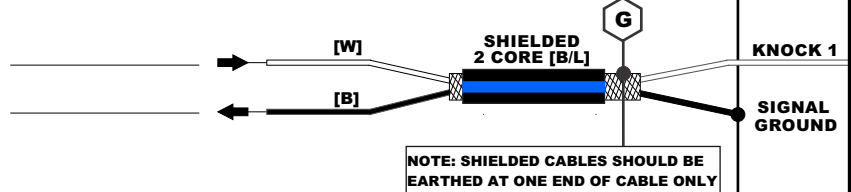

SHIELDED 2 CORE [B/G]

NOTE: SHIELDED CABLES SHOULD BE EARTHED AT ONE END OF CABLE ONLY

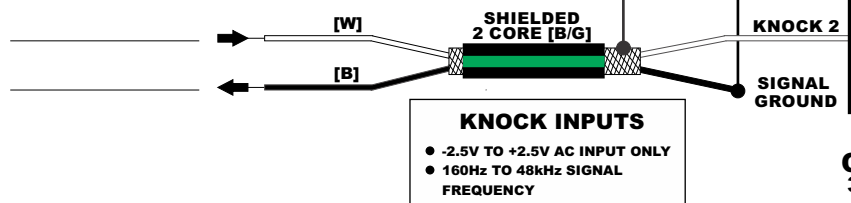

KNOCK INPUTS

- -2.5V TO +2.5V AC INPUT ONLY
- 160Hz TO 48kHz SIGNAL FREQUENCY

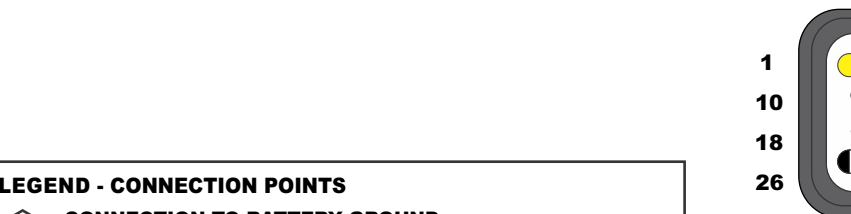

LOOKING INTO CONNECTOR ON NEXUS R3 VCU

NOTES

AVI

11 X ANALOG VOLTAGE INPUTS

- INDIVIDUAL SOFTWARE SELECTABLE 1K PULL-UP TO 5V
- USER DEFINABLE INPUTS CAN BE ALLOCATED TO AVAILABLE FUNCTIONS IN THE SOFTWARE
- 30V MAX INPUT VOLTAGE
- 1000 SAMPLES/SECOND
- 1.5kHz MAX INPUT FREQUENCY
- ALL AVIS CAN BE USED FOR NARROWBAND O2 AND DBW

RECOMMENDED WIRE GAUGE: 22 AWG

INPUT: -10V TO 30V

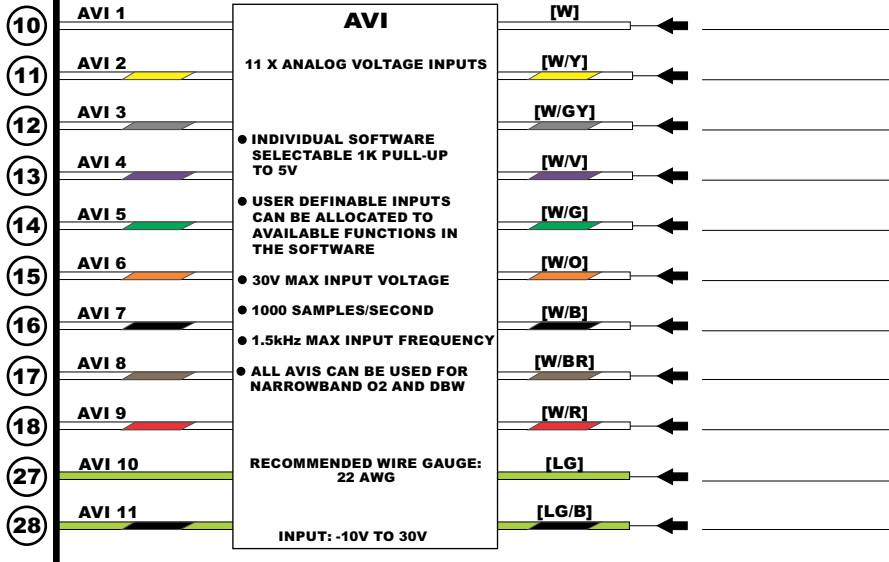

CAN (ISO 11898)

SUPPORTS SPEEDS UP TO 1Mbit/s

HALTECH BUS

- SUPPORTS ALL HALTECH EXPANSION PRODUCTS

VEHICLE BUS

- SELECTABLE PRECONFIGURED VEHICLE CAN INTERFACE
- OBDII COMPLIANT

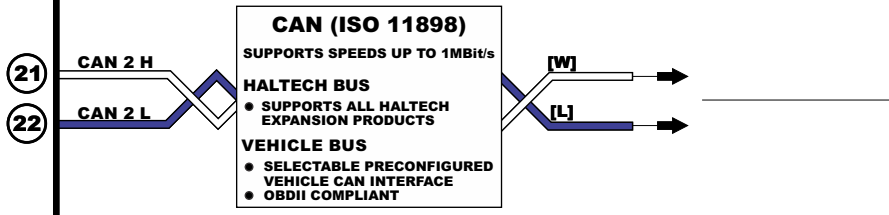

+8V SENSOR SUPPLY

- 200mA MAX OUTPUT CURRENT

+5V SENSOR SUPPLY

- 200mA MAX OUTPUT CURRENT

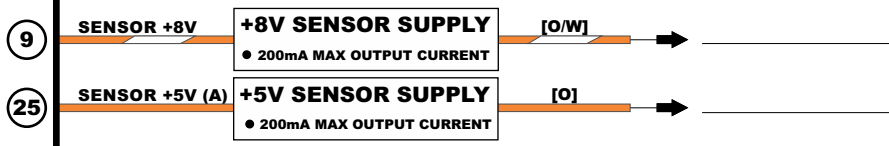

WIDEBAND SENSOR INPUT

COMPATIBLE WITH BOSCH LSU 4.9 AND NTK SENSORS

SELECT WHICH SENSOR IS BEING USED IN THE SOFTWARE

- COMPATIBLE WITH ETHANOL
- MUST BE INSTALLED PRE CATALYTIC CONVERTOR
- OPTIONAL WIDEBAND HARDWARE PACK MAY BE PURCHASED IF REQUIRED (HT-010746 FOR LSU4.9) (HT-010747 FOR NTK)

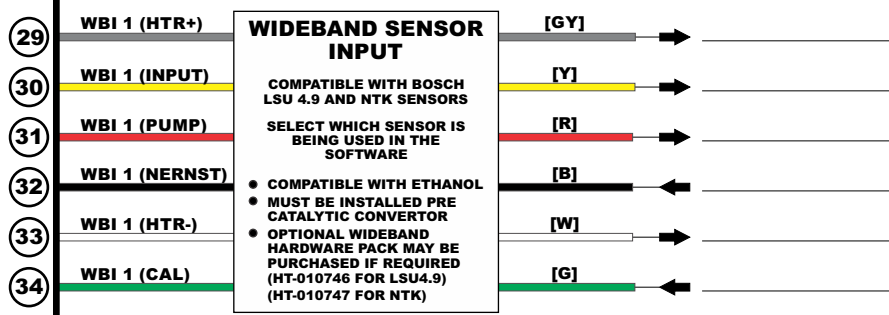

LEGEND - CONNECTION POINTS

G CONNECTION TO BATTERY GROUND OUTPUT ON CONNECTOR A - SHEET 1

H CONNECTION TO ANY HBO ON CONNECTOR A - SHEET 1 (MUST BE ASSIGNED AS +12V ENGINE CONTROL RELAY FUNCTION IN NSP)

LEGEND - WIRE COLOUR

B = BLACK BR = BROWN G = GREEN GY = GREY L = BLUE LL = LIGHT BLUE LG = LIGHT GREEN LY = LIGHT YELLOW O = ORANGE P = PINK R = RED V = VIOLET Y = YELLOW W = WHITE

WHEN TWO COLOURS ARE USED IN A WIRE BY THE ALPHABETICAL CODE, THE FIRST LETTER INDICATES THE BASIC WIRE COLOUR, THE SECOND COLOUR INDICATES THE COLOUR OF THE STRIPE.

NOTES

25A HCO

4 X 25A HIGH CURRENT OUTPUTS

- HIGH/LOW SIDE DRIVE
- 25A MAX CURRENT
- CAPABLE OF 0-100% DUTY
- 1kHz SWITCHING SPEED
- SOFTWARE PROGRAMMABLE FUSE CURRENT, DELAY AND NO. OF RETRIES
- OVERCURRENT PROTECTION

RECOMMENDED WIRE GAUGE: 12 AWG

OUTPUT: BATTERY VOLTAGE OR GROUND

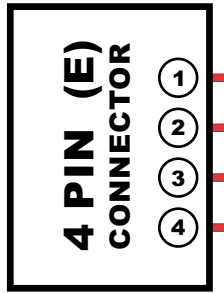

CONNECTOR E 4 PIN DTP

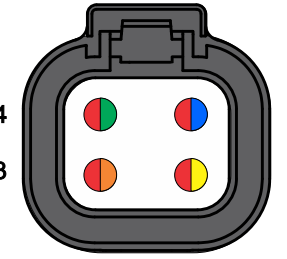

LOOKING INTO CONNECTOR ON NEXUS R3

